

These drawings and specifications are the property of H2W Technologies, Inc. They are issued in confidence and shall not be reproduced, copied, or used without written permission from H2W Technologies, Inc.

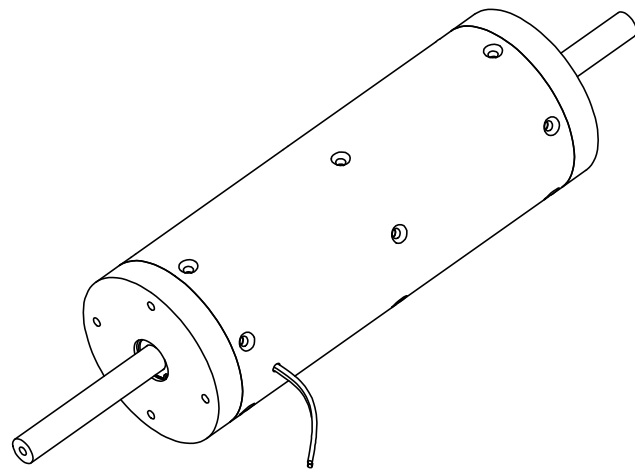
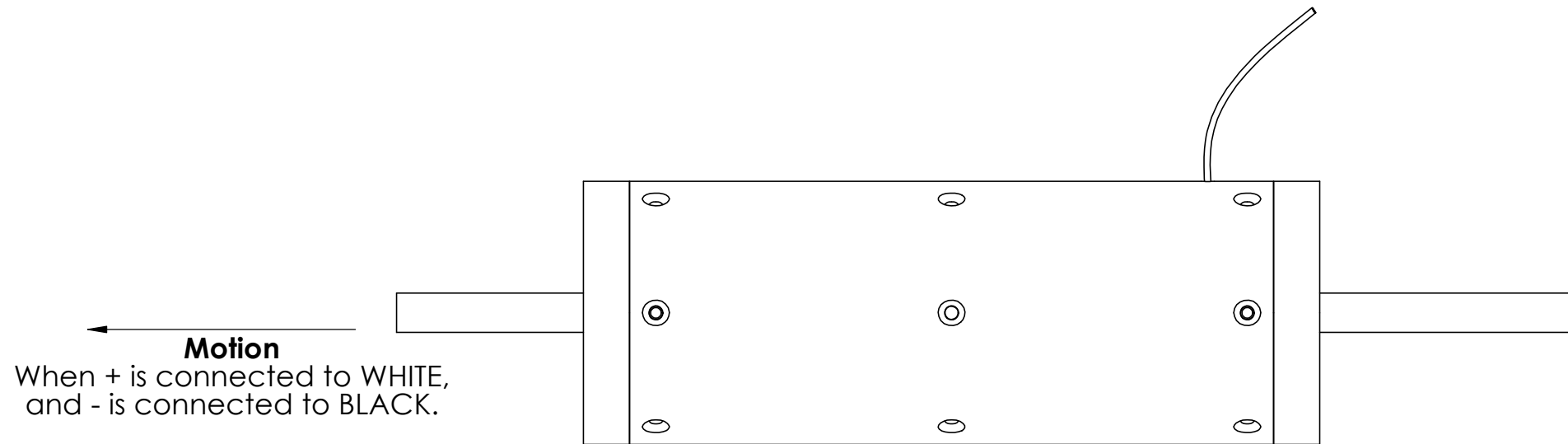
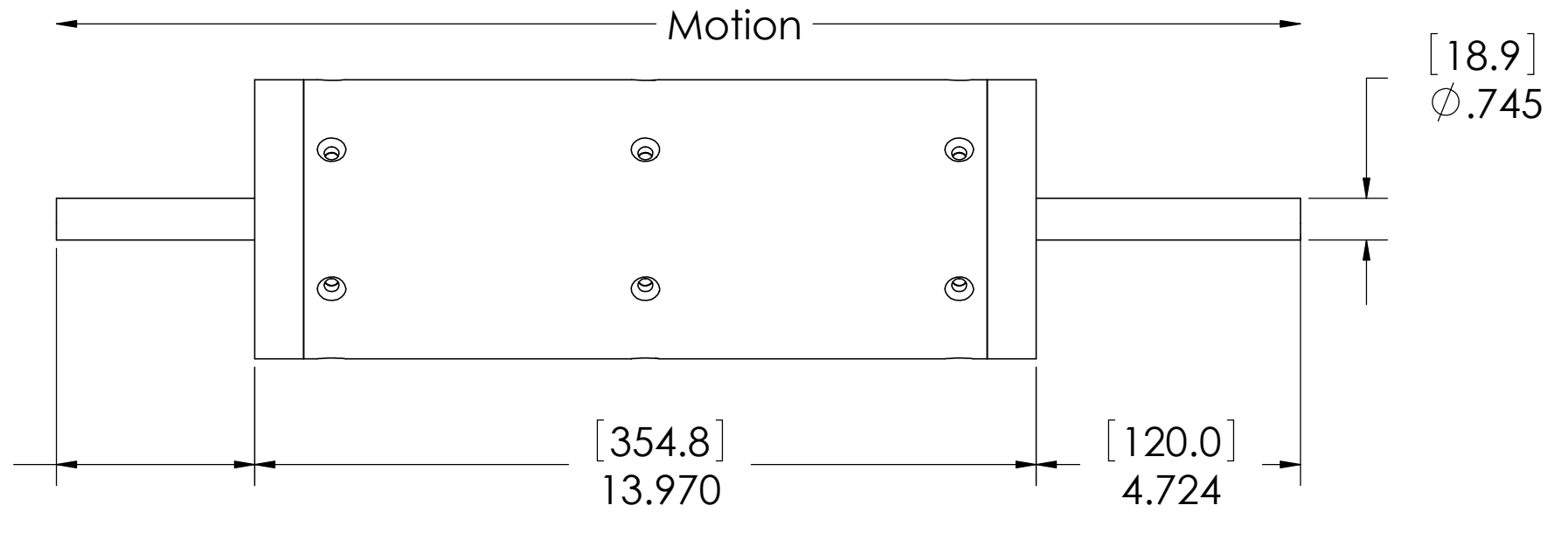
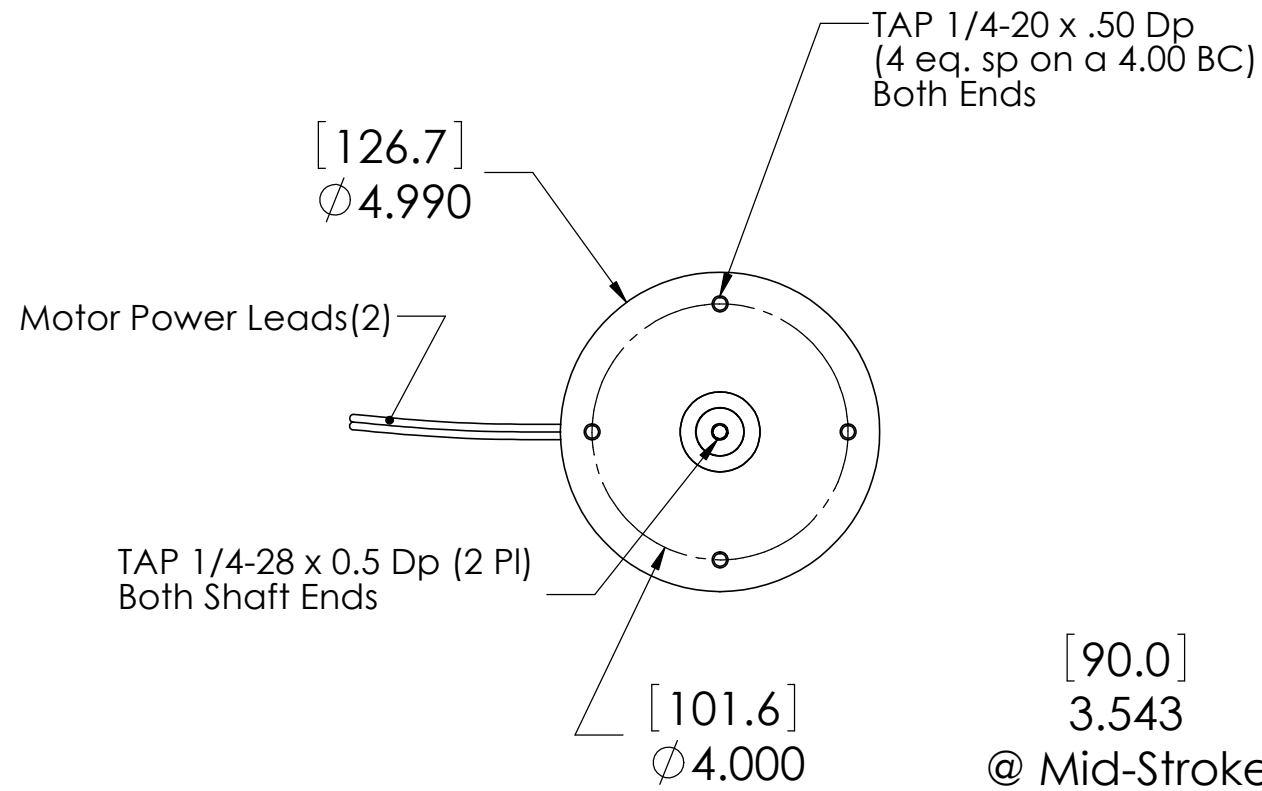

**Specs:**  
 Stroke = 4.0 in  
 Force (Cont) = 68 lbs (300 N) @ 100% Duty  
 Force (Peak) = 204 lbs (900 N) @ 10% Duty  
 Moving Mass = 14.5 pounds

**H2W Technologies, Inc.**

28310-C Ave Crocker Valencia, CA 91355 USA  
 Tel: (661)-702-9346 Fax: (661)-702-9348  
 www.h2wtech.com

TITLE  
**Moving Magnet Non-Comm Linear Actuator  
 Model# NCM40-50-680-2LB**

UNLESS SPECIFIED OTHERWISE: All dimensions are in inches Standard Tolerances are as follows .XXX ±.005 ANGLES ±1° .XX ±.010 FILLETS AND .X ±.020 CORNERS .010 Remove All Burrs and Sharp Edges				MATERIAL			
FINISH				DATE			
DRAWN	DATE	APPROVED	DATE	DRAWN	DATE	APPROVED	DATE
OOG	4-3-08	MPW	4-3-08	OOG	4-3-08	MPW	4-3-08

DWG # **30-0714** REV **C** SHEET 1 of 2

These drawings and specifications are the property of H2W Technologies, Inc. They are issued in confidence and shall not be reproduced, copied, or used without written permission from H2W Technologies, Inc.

<b>MOVING MAGNET NON-COMM ACTUATOR SPECIFICATIONS</b>		
Motor P/N	NCM40-50-680-2LB	
Stroke	4.00"	101.6 mm
Radial Clearance	N/A in	N/A mm
Bearing Type	Recirculating Ball Bushings	
Moving Mass	10.0 lbs	4.54 Kg
Total Mass	40.0 lbs	18.2 Kg
Resistance @ 20C	5.5 ohms	
Inductance @ 20C	9.6 mH	
Electrical Time Constant	1.75 msec	
Motor Constant	7.23 LBS/SQRT(Watt)	32.1 N/SQRT(Watt)
Force Constant	17.2 LBS/Amp	76.4 N/Amp
Back EMF	1.95 V/ips	76.4 V/m/sec
Continuous Force	68 LBS	303 N
Max Power @ 100% Duty	88 Watts	
Peak Force	204 LBS	908 N
Max Power @ 10% Duty	800 Watts	

**H2W Technologies, Inc.**  
 28310-C Ave Crocker Valencia, CA 91355 USA  
 Tel: (661)-702-9346 Fax: (661)-702-9348  
 www.h2wtech.com

UNLESS OTHERWISE SPECIFIED: ALL DIMENSIONS IN INCHES .XXX ANGLES ±1° .XX ±.010 FILLETS AND X ±.020 CORNERS .010 REMOVE ALL BURRS, SHARP EDGES		MATERIAL		TITLE Moving Magnet Non-Comm Linear Actuator Model# NCM40-50-680-2LB	
FINISH		DRAWN OOG	DATE 4-3-08	APPROVED MPW	DATE 4-3-08
DWG #	REV	SHEET			
30-0714	C	2 of 2			